

QUENCH SHOWER

INSTALLATION GUIDE MODEL Q2



Q2 90 X 90 SHOWER SYSTEM

 **SAVE THESE INSTRUCTIONS – PASS ONTO
OWNER / OPERATOR OF QUENCH**

**NOTE: The manufacturer reserves the right to alter specifications
without prior notice.**

QUENCH SHOWER INSTALLATION GUIDE – MODEL Q2

Manufactured by Quench Solutions Pty Ltd
PO Box 41
Patterson Lakes
Victoria
Australia 3197

Phone: (03) 9786 7887
Email: info@quenchshowers.com
Website: www.quenchshowers.com

 **IMPORTANT:** The following information must be read and understood before commencing the installation of the Quench Shower system. If clarification is required on any issue, please contact the supplier before proceeding with installation.

 **SAVE THESE INSTRUCTIONS – PASS TO OWNER / OPERATOR OF QUENCH.**

SYMBOLS



The exclamation point in a triangle signifies an important item. Read the manual concerning the item mark or feature identified.



The lightning flash in a triangle is a warning that hazardous energy is present.



Protective earth terminal is signified by this mark.

 All plumbing and electrical services **MUST** be performed by qualified / licensed personnel in accordance with local and national code / standards.

PREPARATORY

Ensure the Quench Shower system is unpacked carefully and all components are stored in a clean, safe environment. Check all surfaces to ensure no damage has occurred during transportation and handling.

Avoid heavy, sharp or abrasive objects from coming into contact with the smooth, gloss surfaces of the shower base and fixtures.

 Refer to the plumbing and electrical preparatory section of this manual to ensure that services are provided for, prior to commencement of installation.

- Check the **HOT** and **COLD** water supply lines are located in the correct position.

- Check the trapped **WASTE** (drain) line is located in the correct position and allowance is made to gain access beneath the shower base, to connect the waste once set in position.



- Check the dedicated **ELECTRICAL** supply line protected via an Earth Leakage Circuit Breaker (ELCB) is located in the correct position. See drawing **No: Q2-004 2 of 5**.

POSITIONING AND FIXING THE SHOWER BASE

The Quench Shower base is unique in that it has a reservoir and a pump box (sump) which sits below the level of the shower base. This means there is a requirement for a floor pit, below floor level, of approximately 250mm deep. This pit beneath the reservoir allows for the waste (drain) connection. **See drawing No: Q2-004 2 of 5.**



IMPORTANT: Ensure allowance is made (floor pit) to gain access beneath the shower base to connect the waste once the base has been set in position.

The pump box is to be recessed into the back wall cavity; this cavity is to have a 375mm approx deep clearance. This cavity is to have a minimum clearance height of 1915mm measuring from the top flange of the pump box. This is to allow for the positioning and recessing of the equipment tower, the tower recesses into wall cavity by approximately 370mm. **See drawings No: Q2-004 2 of 5 and Q2-004 4 of 5.** A distance of approximately 150mm from the tile bead to the flange of the equipment tower flange is to be allowed for. This distance enables a row of tiles to be placed between the shower base and the equipment tower for aesthetic purposes.

TILE BEAD

The shower base incorporates a moulded tile bead on three sides (not on the front entry side). The tile bead is designed to allow an appropriate tile substrate (wet area wall lining) to sit over this bead. The tile substrate is to also allow for the tile to sit over the bead providing a water splash barrier. A silicon sealant is to be applied between the tile work and the shower base.

INSTALLATION

1. **Trial fit** - Once the shower base has been trial fitted, confirm the floor onto which the shower base is to be located is flat and has a level surface. Ensure there is no loose gravel, stones or sharp objects on this surface as this will cause damage to the shower base when in use. Remove the front cover panel from the equipment box by unscrewing the fixing caps. Be careful when removing the cover as there are flexible plumbing and electrical connections that will require disconnecting during the installation of the equipment tower. Ensure disconnections are recorded so they are reconnected correctly when relocating the front cover panel. Ensure the equipment tower will locate and recess above the shower base in accordance with **drawings No: Q2-004 2 of 5 and Q2-004 4 of 5.**
2. Fit the pop-up waste provided to the shower base moulding. Apply a thin bead of silicon sealant to the waste flange so that a silicon seal is made when located against the base moulding. The rubber gasket locates on the underside of the base **NOT** inside the shower base, tighten firmly by hand. Use a clean dry soft cloth to remove excess silicon.
3. Lay a moisture barrier (plastic sheet) on floor to overlap intended shower base installation area – this will prevent moisture from the support bed being absorbed into flooring.

4. Spread a stiff mortar mix (suggest 4:1 sand and cement with wetting agent) over complete area to be occupied by shower base and the pump box (sump).

NOTE: Ensure the pump box (sump) the moulded part of the shower base is also properly supported by mortar mix. This will provide insulation / noise reduction during pump operation. It is also recommended expanding foam be used to surround the pump box – externally. Do not apply foam to pump or fittings located in the pump box. Foam will provide additional noise reduction during pump operation.

5. Locate the shower base and push down into mortar pad until level in all directions. Ensure the shower base gelcoat surface is protected against surface damage, scratching etc. During this procedure use a soft cloth sheet or similar and make certain that there is no sand or grit between the sheet and the gelcoat surface. To avoid structural damage and ensure reliable water run off, it is important the base is adequately supported and therefore where the base support instructions can not be adhered to then an appropriate, alternative support method must be provided.



IMPORTANT: Before proceeding, check water run off from the shower base to waste outlet (drain) is satisfactory. It is recommended the shower base is not stood on or excessive weight is applied during the curing of the mortar pad as this may create an air gap between the base and mortar pad once cured.

6. The pump box must be firmly secured in-place by the moulded flanges and well supported from the underside - a mortar pad and / or dense block-work is ideal as this will reduce resonance / vibration during pump operation. The pump and components contained in the skid weigh approximately 10kg (22lbs).
7. Proceed to construct frame work around the shower base and allow for the equipment tower positioning and fixing.

POSITIONING & FIXING THE EQUIPMENT TOWER

The equipment tower contains the Quench shower operating system eg; electronic controls, heater, sanitizing solution reservoir and plumbing fixtures. The bottom end of the tower is open and provides access to the pump box. When in final position, the tower and components contained in the tower weigh approximately 30kg (66lbs). There is a cut-out on the left hand side of the equipment tower; this is to allow for entry of hot and cold water and electrical supply line.

The equipment tower front cover panel is to be removed during the positioning and fixing of the equipment tower, this is achieved by unscrewing the chrome fixing caps. Ensure all equipment inside the tower is protected against damage and exposure to dirt, grit, tile debris etc. Store the front cover panel in a safe, clean environment.

The tower is to be framed and recessed into the back wall of the shower surround. The tower is to sit approximately 150mm above the tile bead. **See drawings No: Q2-004 2of 5 and Q2-004 4 of 5.** Secure the tower firmly into position using rust resistant screws and an appropriate adhesive. The distance between the pump box and the tower allows for a row of tiles – enhancing the aesthetics of the shower enclosure. **See drawings ‘C’ and ‘D’.**



IMPORTANT: The tower must be installed vertical, straight and plumb. The tower's moulded seal face is to sit as shown in **drawing ‘B’**. The tower's seal face matches up with the tower cover panel when finally secured in-place. The seal is to prevent water ingress

when shower is operating. If required, spread the tower's moulded flange to ensure straight vertical edges when secured to frame work.

VENTALATION

Ensure the cavity in which the equipment tower is installed is not air-tight as ventilation to the water pump is required.

EQUIPMENT TOWER COVER PANEL - DECORATION

The cover panel is available factory tiled, glass lined, stainless steel or in a variety of finishes. The panel is supplied standard without decorative finish and therefore will require decorating. The shower fixtures will require removing and replacing and sealing to cover panel following this procedure.



IMPORTANT: When re-fitting the equipment tower's front cover panel back onto the equipment tower, ensure the seal face rubber has not been damaged and no debris or any interference will prevent the cover panel from sealing correctly. Push on panel to compress rubber seal during re-fitting – tighten caps firmly to avoid water leaks around seal.

TILING SURFACES

It is important a suitable wet environment, high quality tile adhesive is used. Ensure tiles are run down to the shower base and flush up to the equipment tower as shown in **drawing 'B'**. Use a high quality flexible grout suitable for shower conditions. Select a grout with mould inhibitors incorporated. Grout is not water proof – it is essential a grout / tile sealer is applied to surfaces prior to using the shower.

LOCATING THE SANITIZING RINSE CONTROL BUTTON

An air-button control is supplied with the Quench shower system. This air-button is to be located external of the shower cubicle and convenient to press when exiting the shower. This air-button activates the automatic sanitizing rinse cycle once the bather has finished a shower session. Simply drill the surface to which the button is to be mounted eg; wall or hob. The plastic air switch tube which is connected to the electrical termination box must be routed through to the air-button control location, connect the tube to the button and then attach the button to the mounting surface using silicon sealant.

PLUMBING CONNECTION



IMPORTANT: All plumbing services **MUST** be performed by qualified / licensed personnel in accordance with local and national code / standards.

1. When removing the equipment tower cover panel avoid pulling on the panel and in-turn the plumbing connections.
- 2a. Connect the Quench water pump which is located in the pump box (sump) to the plumbing which is attached to the shower base behind the equipment panel. **See Figure 1.** Ensure the pipe has the silver thimbles located in each end of the pipe. The grey plastic pipe **MUST** be pushed firmly down into the grey female union that is fitted to the pump outlet and the other end pushed up into the grey female union that is fitted to the heater inlet. **DO NOT** un-screw and remove the grey female unions – simply un-screw them two turns and push the pipe down firmly into the union. It should push in approximately 25mm – then re-tighten the union by hand only.
- 2b. Connect the flexible fresh water flush hose from the rinse solenoid valve located on the cold water inlet circuit to the water pump suction manifold which is located in the pump box (sump). **See Figure 2.**

- 2c. Connect the plastic bleed tube from the shower mixer take off plumbing to the water pump suction manifold which is located in the pump box (sump). **See Figure 3.**
- 2d. Connect the plastic sanitizer tube from the sanitizer container solenoid valve to the water pump suction manifold which is located in the pump box (sump). **See Figure 4.**
3. Connect 15mm (½ inch) hot and cold main water supply lines to the Quench plumbing. Flexible hose connections are recommended. 350-950 kpa (50 – 100psi) **MAX.** **See Figure 5.**
4. Connect 40mm (1 ½ inch) waste (drain line) to shower base. The pop-up waste (drain) is supplied.
5. After the equipment tower front panel has been tiled, the shower fixtures / controls must be re-fitted and sealed to the tiled surface. An appropriate sealer eg: silicon sealant is to be used to ensure water tight seal. The Quench display / control panel must also be completely sealed to the tiled surface using silicon sealant.

ELECTRICAL CONNECTION



IMPORTANT: All electrical services **MUST** be performed by qualified / licensed personnel in accordance with local and national electrical code / standards.

STANDARD SPECIFICATION

The **Standard Specification** Quench shower system incorporates a water recirculating pump 540 Watts @ 230 Volts and a heating element 4080 Watts @ 230 Volts. The heating element is designed to maintain water temperature that is being recirculated and therefore operates as required – typically the heater pulses on / off during the Quench auto-mode (recirculation) to raise the water temperature by only a few degrees. Frequency of pulsing is relevant to the selected shower temperature set at the control panel.

1. Terminate the 220/240 Volt, 50Hz, 20 Amp, single phase dedicated electrical supply in the electrical termination box provided. The electrical termination box is located in the equipment tower. Ensure the box lid is replaced and secured to provide seal.

BOOST SPECIFICATION - OPTIONAL

The **Boost Specification** Quench shower system incorporates a water recirculating pump 885 Watts @ 230 Volts and a heating element 6120 Watts @ 230 Volts. The heating element is designed to maintain water temperature that is being recirculated and therefore operates as required – typically the heater pulses on / off during the Quench auto-mode (recirculation) to raise the water temperature by only a few degrees. Frequency of pulsing is relevant to the selected shower temperature set at the control panel.

1. Terminate the 220/240 Volt, 50Hz, 30 Amp, single phase dedicated electrical supply in the electrical termination box provided. The electrical termination box is located behind the equipment panel. Ensure the box lid is replaced and secured to provide seal.



IMPORTANT: The dedicated electrical supply line **MUST** be protected by an ELCB (Earth Leakage Circuit Breaker) with a maximum trip current of thirty milliamps.



FUSES: Circuit protection is provided by internal fuses which are intended to be serviced by authorized service personnel only. Fuse locations are as follows (all fuses contained in electrical termination box). Replace only with fuse of same type rated as marked.

QUENCH DISPLAY / CONTROL PANEL

Connect the flying lead from the Quench display / control panel that has been silicon sealed to the front cover panel to the control board inside the electrical termination box. The Ground / Earth cable from the display / control panel must be connected to the copper busbar. **See Figure 6.**



TESTING

Once electrical and plumbing connections have been made it is important to test the Quench shower system. The front cover panel is to have all plumbing connections made but is to remain removed from the tower so that visual inspection into the equipment tower can be carried out thoroughly during the test procedure. Ensure that all pipe work and connections can be inspected during water testing.

1. First ensure the shower surfaces are clean from grit and debris.
2. Ensure the cloth strainer is located over suction fitting and is clean.
3. Fill the sanitizer container through the sanitizer fill cap located on front cover panel, rotate the cap and remove. Fill only with undiluted Q-San solution – five litre capacity.
4. Connect electrical supply to the Quench shower.
5. Connect hot and cold water supply to the Quench shower.
6. The equipment tower's front cover panel may be loosely located in place.
7. With the pop-up waste in the open position (waste is in up position) operate the shower in normal shower mode by manually lifting the lever on the shower mixer. Allow the water to flow through the shower head and adjust water temperature. Allow shower to operate in normal shower mode long enough to visually inspect all plumbing for leaks.

NOTE: When the shower is activated in normal mode by lifting the shower mixer, water will flow from the suction for approximately fifteen seconds before the suction valve automatically closes and directs all the shower water through the shower head. The suction is located in the reservoir. The water flowing from the suction will shut off sooner if the water temperature flowing through the system reaches 33 Celsius.

8. Whilst the shower is still operating and water temperature is approximately 38 Celsius, close the waste by pushing down on it. Allow the reservoir in the shower base to fill with water to the top of the reservoir then turn shower off by pushing down on the shower mixer.
9. Immediately press the on / off button on the control panel to activate the Quench auto-mode (recirculation) – water from the reservoir will now be pumped through the shower head. The heater can be adjusted at the control panel, set the maximum temperature by pressing the up arrow. Allow the auto-mode to operate for approximately five minutes – a five minute timer is incorporated in the systems software. Press the on / off button several times throughout operation to stop and start the auto-mode. Visually inspect all plumbing for leaks.

NOTE: If a time delay of more than three minutes is allowed from when the auto-mode stops operating (system is turned off) then normal shower mode will have to be operated for at least five seconds, then turned off before the Quench auto-mode can be re-started.

10. Following the testing procedure simply drain the reservoir by opening the pop-up waste.
11. Activate the sanitizing rinse cycle by pressing the air-button that is mounted external of the shower cubicle. Once pressed water will flow from the shower head for a few seconds. Sanitizing solution will then be automatically injected into the systems plumbing circuit. The system will then automatically drain, after a sixty second time delay.
12. Following successful testing the front cover can now be located and secured in place. Ensure that the rubber seal on the back of the cover panel is not damaged. Push the cover panel to compress the rubber seal during tightening of the chrome caps.

NOTE: If any leaks are identified or suspected malfunction of the system occurs, disconnect the water and electrical supply to the system and immediately contact the supplier.

SHOWER SCREEN

Contact local shower screen supplier to measure and quote, supply and fit shower screen of your choice.

Figure 1.



Figure 2.



Figure 3.

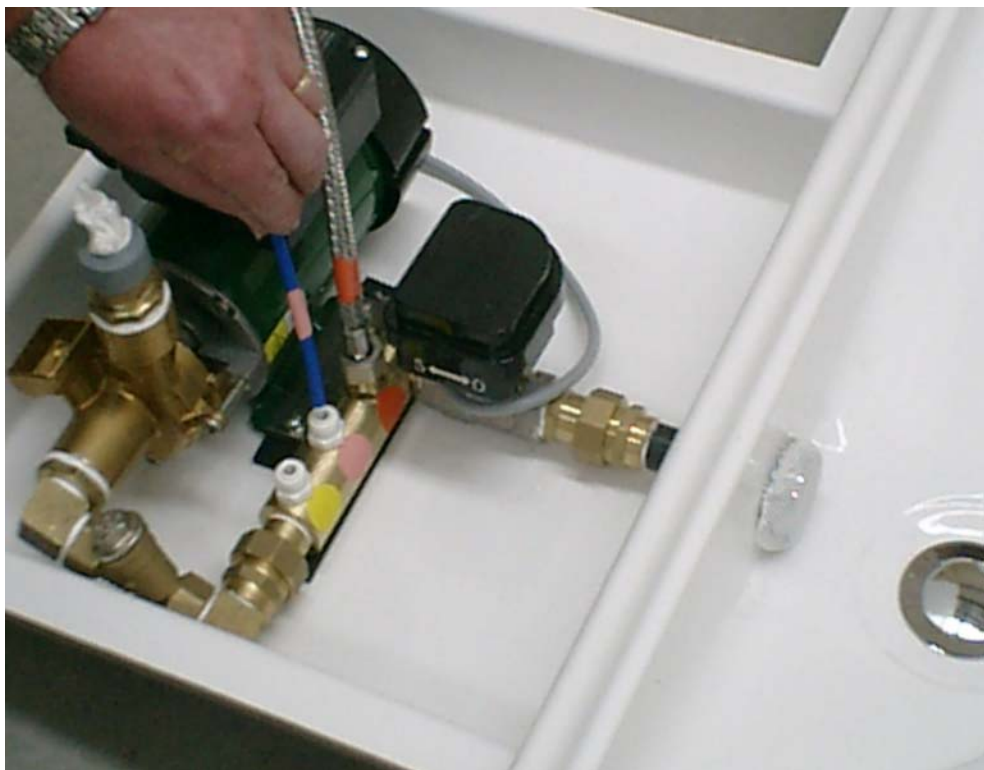

Figure 4.



Figure 5.



Cold Water Supply

Hot Water Supply

Heater to Pump Connection

Figure 6.

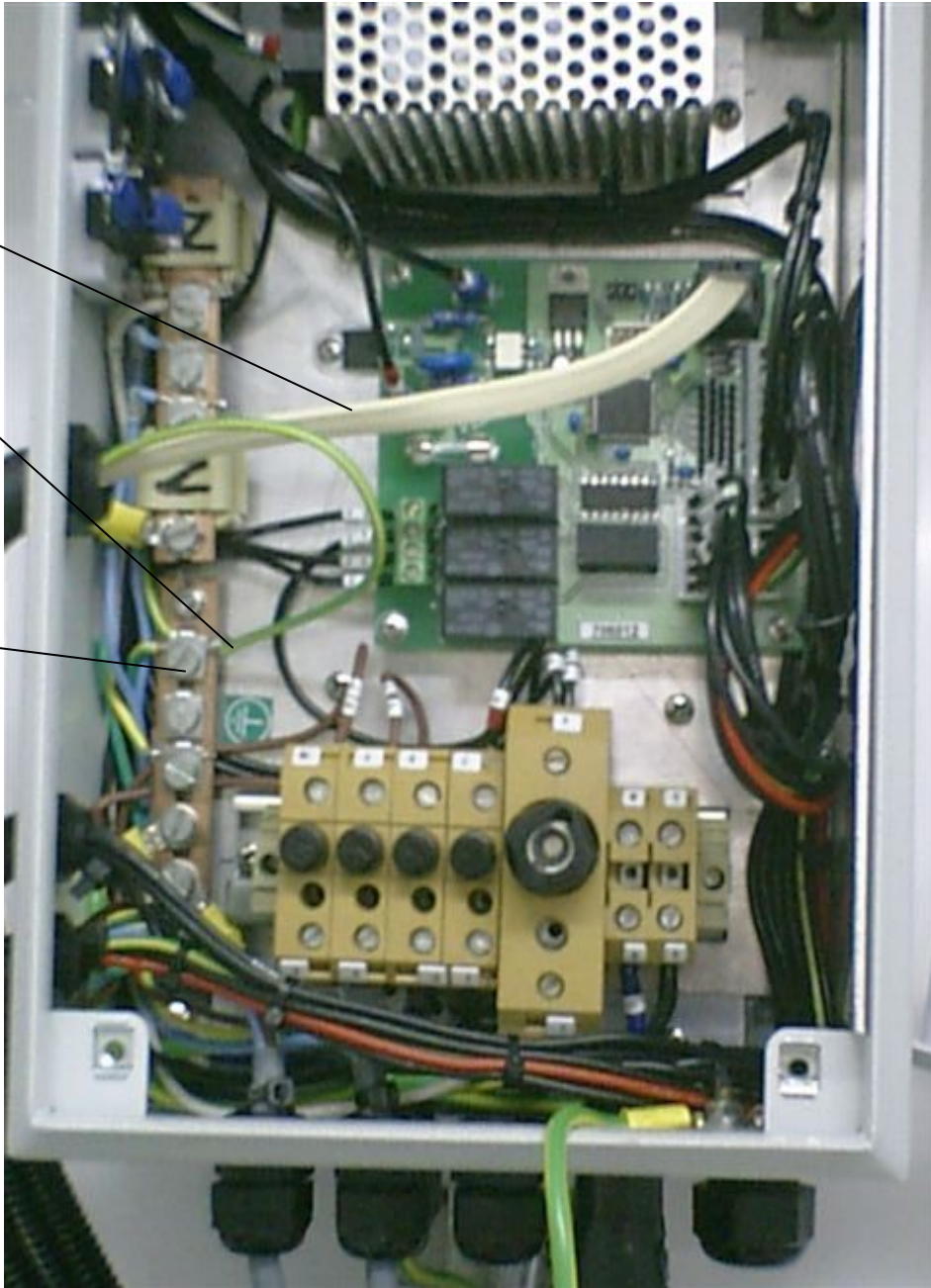

**Quench Display
/ Control Panel
flying lead.**

**Quench Display
/ Control Panel
ground earth.**

**Ground / Earth
copper busbar.**

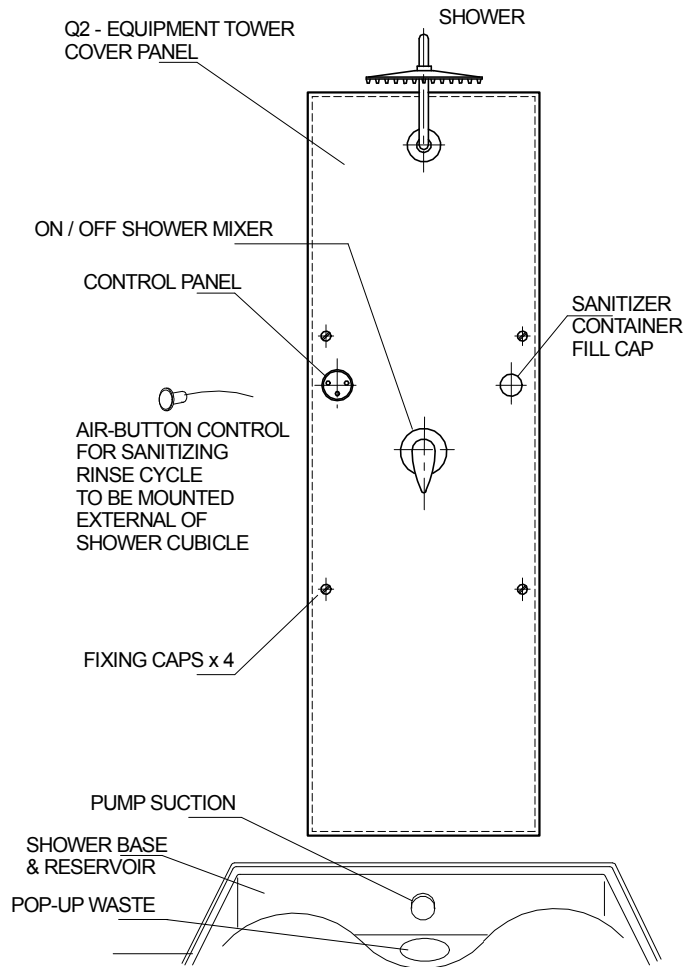
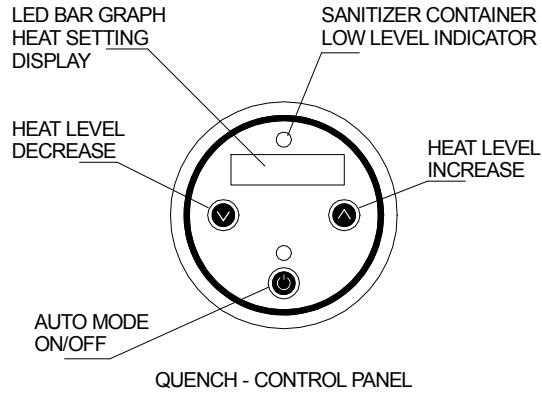

NOTE: SHOWER FIXTURES
MAY VARY ACCORDING TO
CUSTOMER REQUIREMENT

Q2 - CONTROL PANEL - INSTALLATION GUIDE QUENCH SHOWER

SEAFORD VICTORIA AUSTRALIA

ph: (03)9786 7887 www.quenchshowers.com

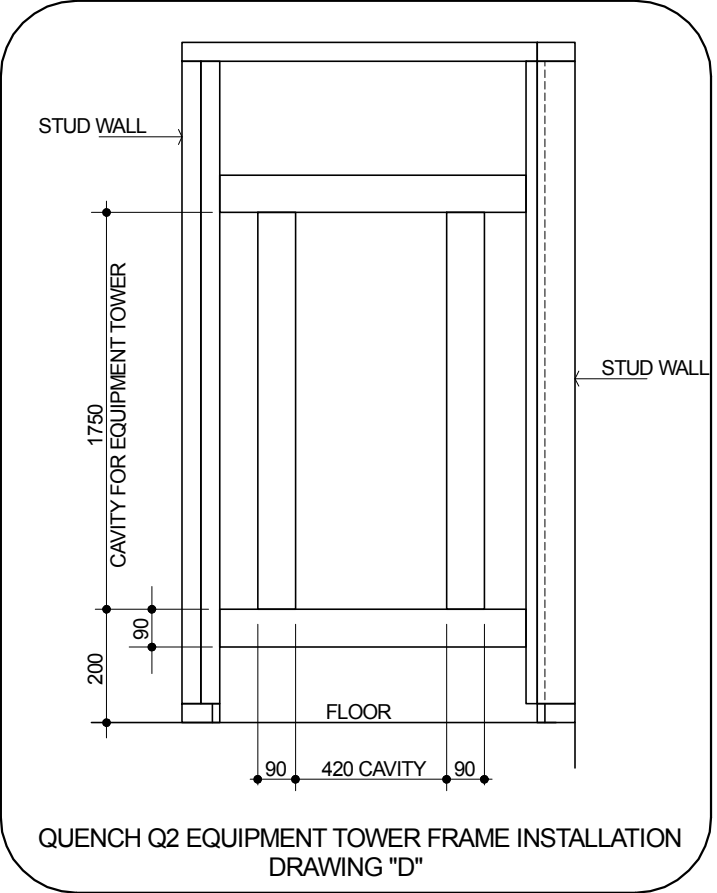
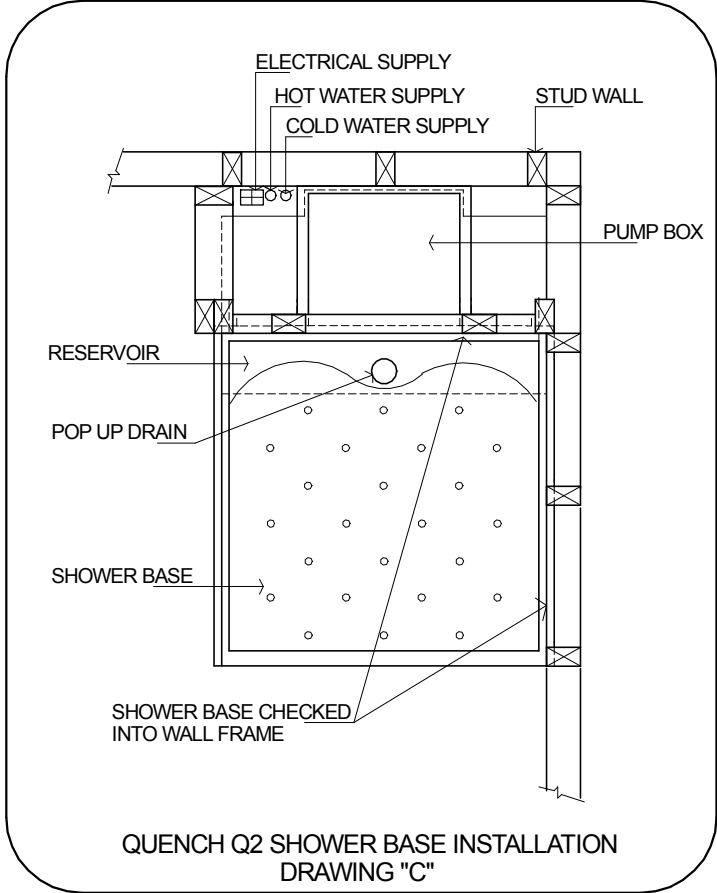
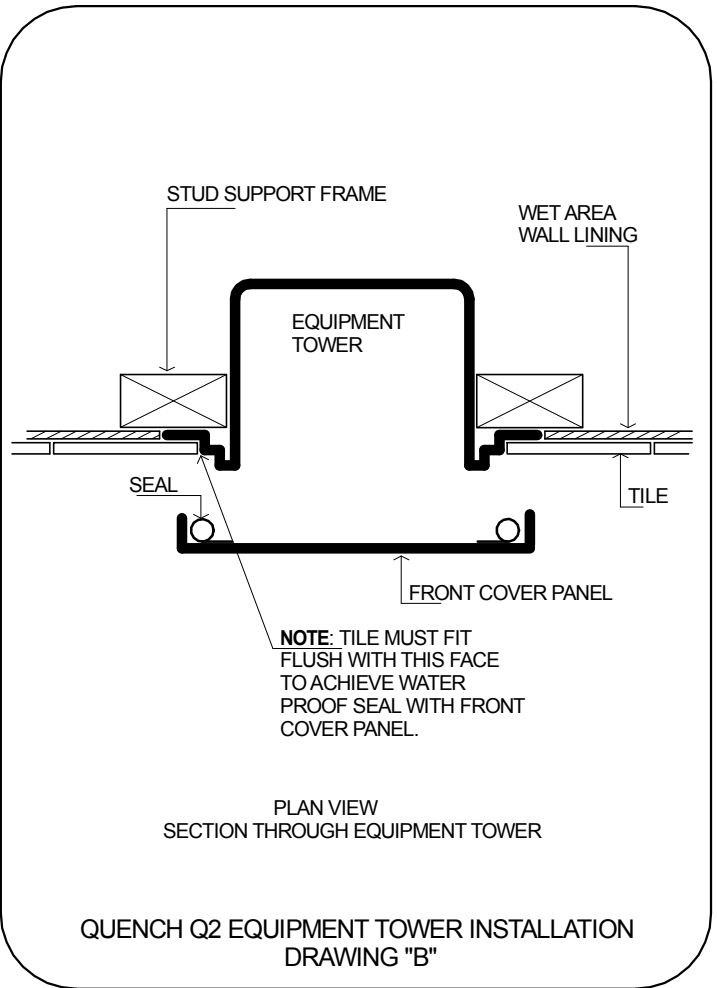
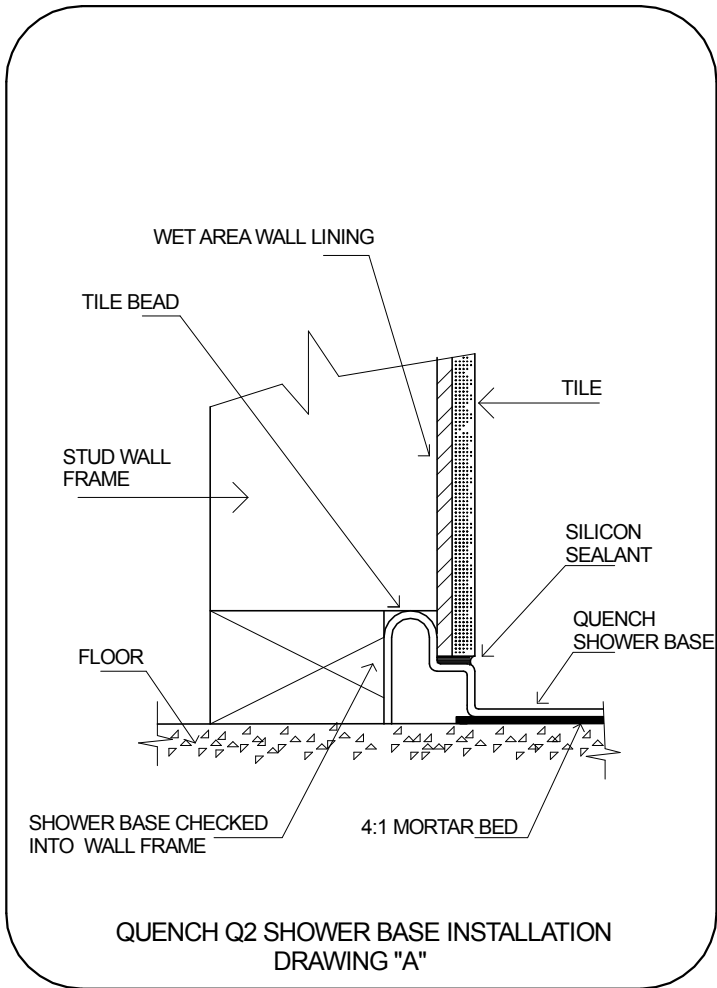

QUENCH Q2 - SHOWER INSTALLATION GUIDE

SEAFORD VICTORIA AUSTRALIA

ph: (03)9786 7887 www.quenchshowers.com

THIS DRAWING IS TO BE USED AS A GUIDE ONLY. THE MANUFACTURER RESERVES THE RIGHT TO AMEND WITHOUT NOTICE 23 JULY 2007



Installation Overview - Model Q2

1. The Q2 Quench Shower model is supplied in 2 pieces – a moulded Shower base and an equipment tower. The shower base is available in varying size and colours. The equipment tower houses the Quench operating system - heater, plumbing and electronic control system. The tower's removable front cover panel has a smooth flat surface to accommodate tile, stainless steel, glass or alternative decorative finish that is to be added on-site.
2. The shower base incorporates the unique Quench reservoir and has the re-circulating pump mounted within the pump box, the pump box is attached to the base. The pump box is to be recessed into the wall cavity of the building to line up with the equipment tower that is also to be recessed into the wall cavity. The pump box recesses into the wall cavity by 370mm and the equipment tower by 335mm
3. A floor pit is to be formed in the slab floor to accommodate the shower base reservoir, pump box. and to allow access to drain connection under shower base.
4. The shower base is to be located, secured and sat on an appropriate support bed. The pump box is to be recessed into the wall cavity by 370mm.
5. The equipment tower is to be located and secured in place centre of the base directly above the pump box. A tile width (approx 150mm) between the shower base and the equipment tower must be allowed for. The shower walls are to be constructed around the shower base and the equipment tower. The tile substrate, tile, grout and sealer is then to be applied.
6. The pump and the equipment tower are then to be connected – this is done by gaining access to the inside of the equipment tower by removing the equipment tower's front cover panel (4 screw caps), connection can then be made. Access to equipment is through the towers front cover panel and from inside the shower enclosure – access to equipment from behind the equipment tower is not required
7. 15mm (1/2 inch) hot & cold water supply lines enter the equipment tower through a cut out window located on the left hand side of the tower. Connection to the equipment tower is then made by qualified plumber in accordance with local and national plumbing regulations.
8. A 40mm (1 1/2inch) drain connection to shower base is to be made by qualified plumber in accordance with local and national plumbing regulations.
9. A 20 Amp single phase dedicated electrical supply via an ELCB is to enter the equipment tower and be terminated inside the electrical box provided. All electrical work must be performed by a qualified electrician in accordance with local and national electrical regulations.

Note: A Boost option is available this requires a 30Amp electrical supply.

Refer to Installation drawings and guide.

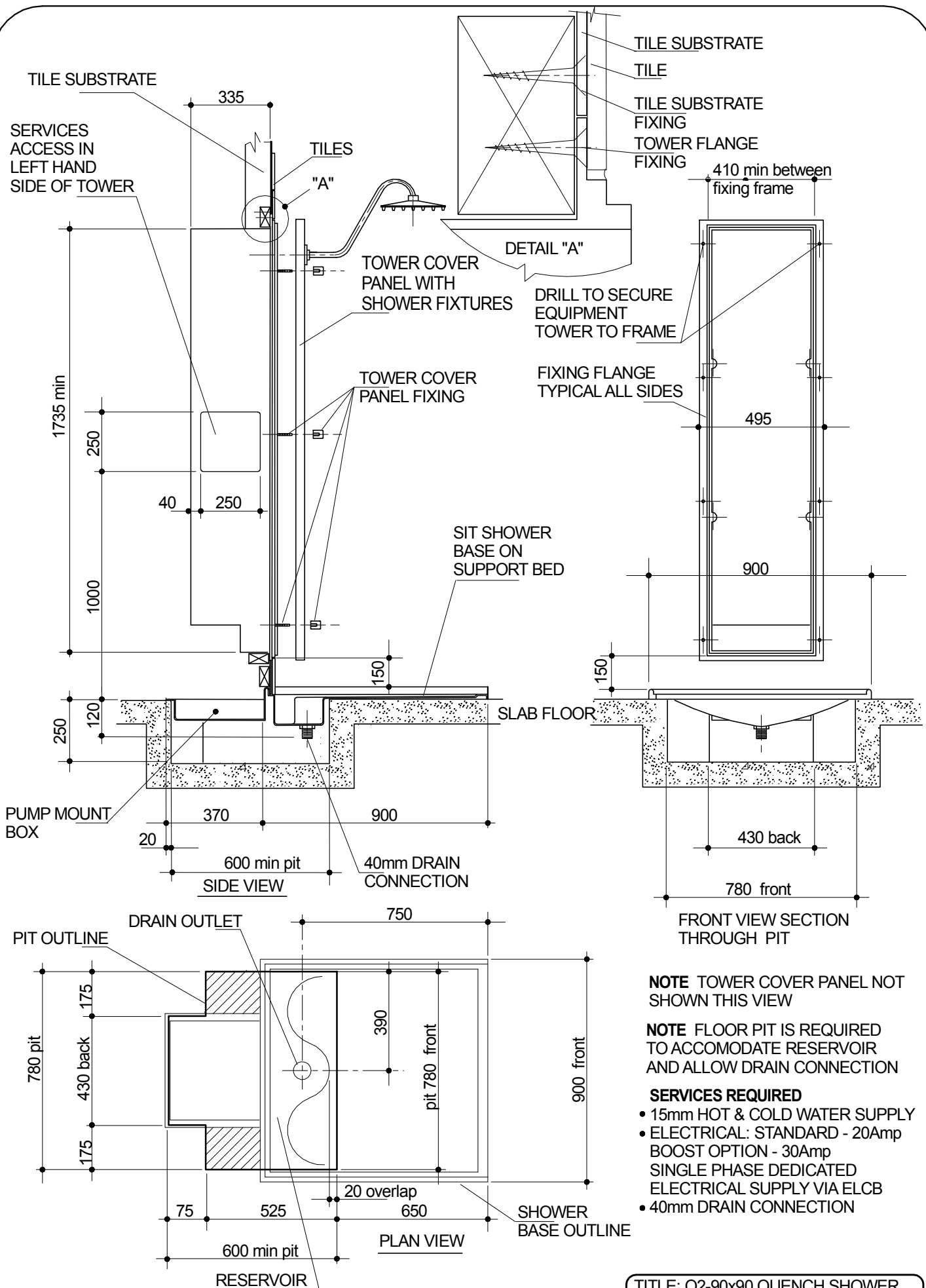

NOTE TOWER COVER PANEL NOT SHOWN THIS VIEW

NOTE FLOOR PIT IS REQUIRED TO ACCOMODATE RESERVOIR AND ALLOW DRAIN CONNECTION

- SERVICES REQUIRED**
- 15mm HOT & COLD WATER SUPPLY
 - ELECTRICAL: STANDARD - 20Amp BOOST OPTION - 30Amp SINGLE PHASE DEDICATED ELECTRICAL SUPPLY VIA ELCB
 - 40mm DRAIN CONNECTION

TITLE: Q2-90x90,QUENCH SHOWER BASE & TOWER INSTALLATION CONCRETE SLAB

DRAIN CONNECTION ACCESS AREA

QUENCH SOLUTIONS PTY LTD
Melbourne Australia

ALL DIMENSIONS IN MILLIMETERS

ph: (03)9786 7887 www.quenchshowers.com

SCALE: 1:20 DRG No. Q2-004 2of5

NOTE. THIS DRAWING IS TO BE USED AS A GUIDE ONLY AND IS SUBJECT TO CHANGE WITHOUT NOTICE 13.09.07

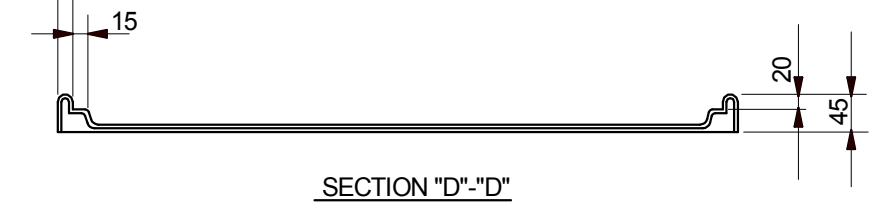
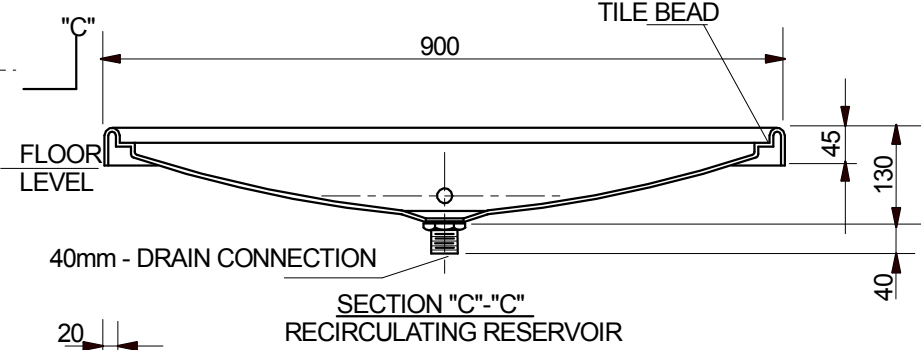
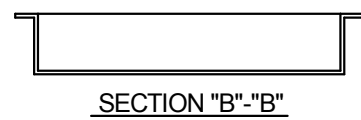
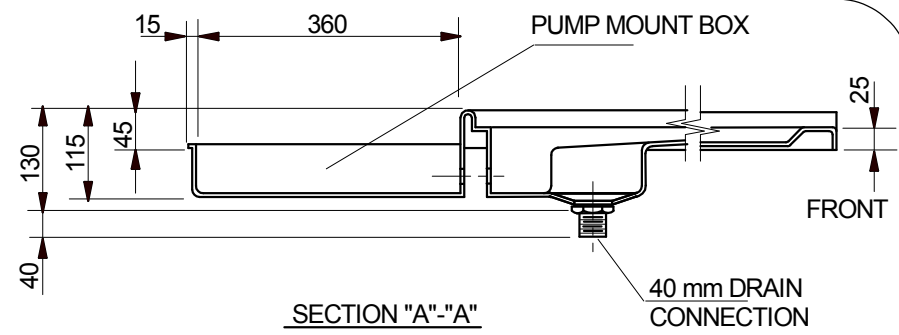
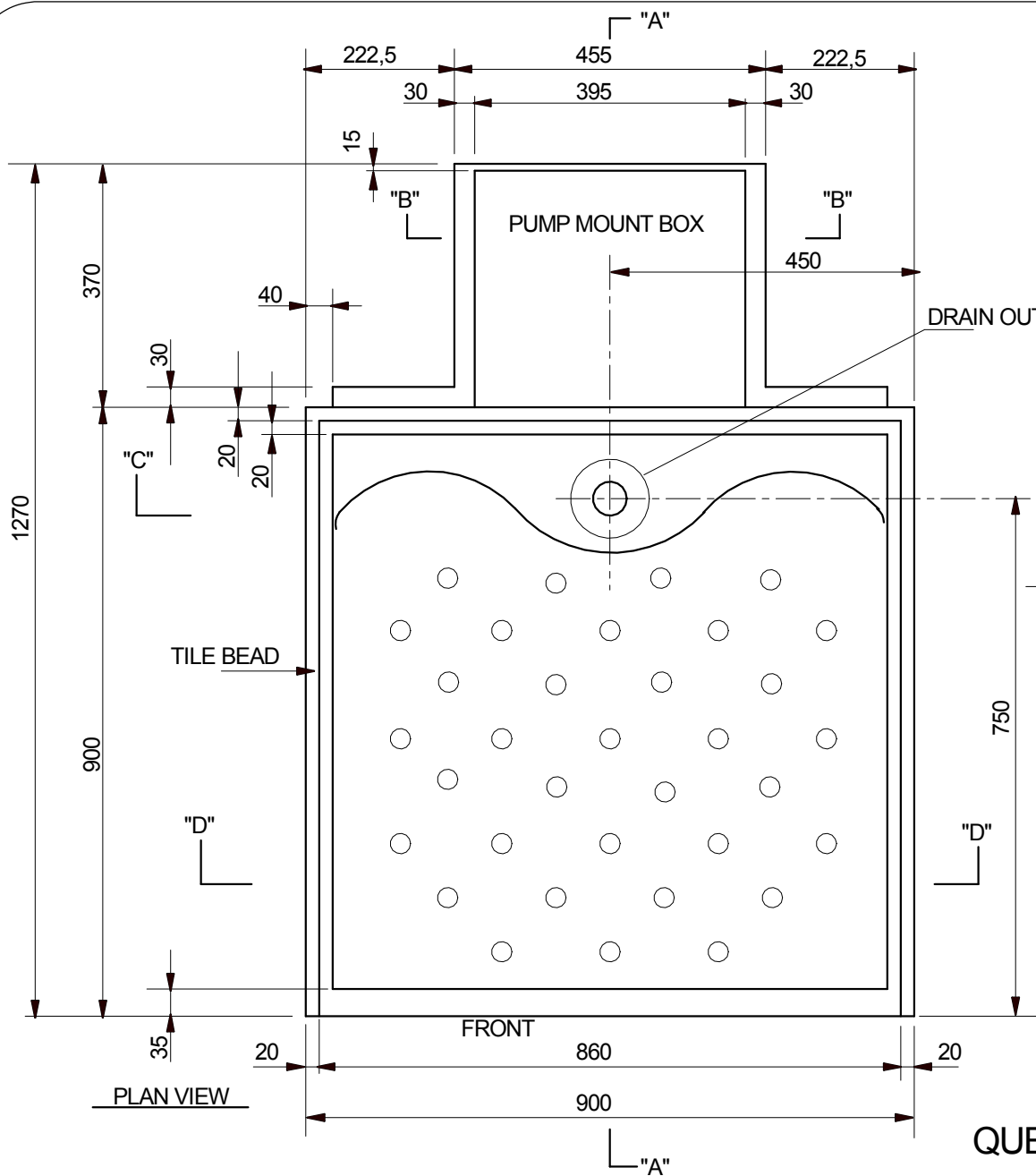

TITLE: Q2 SHOWER BASE 90x90

QUENCH SOLUTIONS PTY LTD
Melbourne Australia

ph: (03)9786 7887 www.quenchshowers.com

● ALL DIMENSIONS IN MILLIMETERS

MATERIAL: MOULDED POLYESTER FIBREGLASS

Scale: 1:5

DRG No. Q2-004 3of5

NOTE. THIS DRAWING IS TO BE USED AS A GUIDE ONLY AND IS SUBJECT TO CHANGE WITHOUT NOTICE

DRILL FIXING HOLES IN FIXING FLANGE DURING INSTALLATION

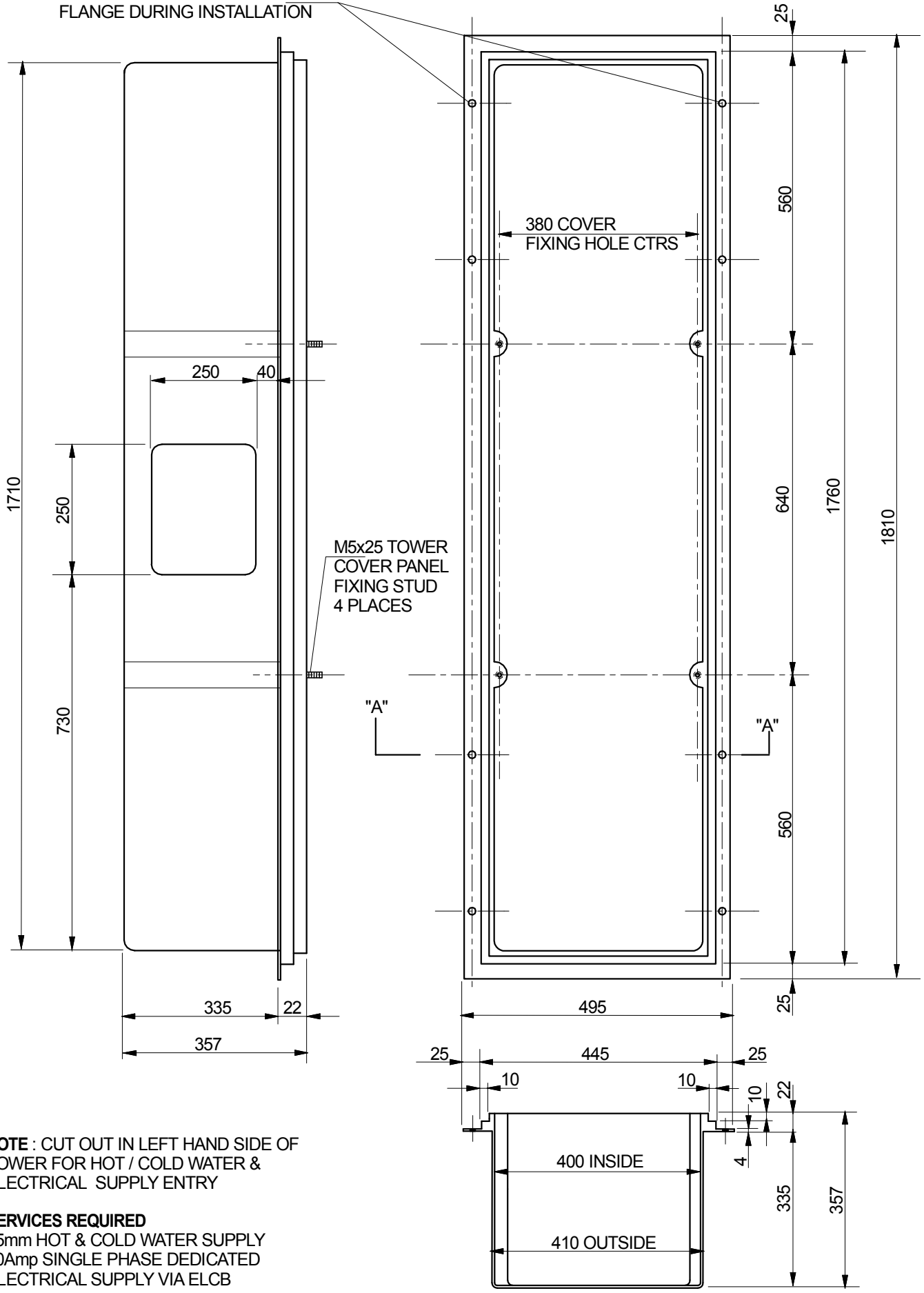

NOTE : CUT OUT IN LEFT HAND SIDE OF TOWER FOR HOT / COLD WATER & ELECTRICAL SUPPLY ENTRY

SERVICES REQUIRED

- 15mm HOT & COLD WATER SUPPLY
- 20Amp SINGLE PHASE DEDICATED ELECTRICAL SUPPLY VIA ELCB

SECTION "A"-"A"

TITLE: EQUIPMENT TOWER

QUENCH SOLUTIONS PTY LTD

Melbourne Australia

ph: (03)9786 7887 www.quenchshowers.com

ALL DIMENSIONS IN MILLIMETERS

MATERIAL : MOULDED POLYESTER FIBREGLASS

SCALE: 1:5

DRG No. Q2-004 4of5

NOTE. THIS DRAWING IS TO BE USED AS A GUIDE ONLY AND IS SUBJECT TO CHANGE WITHOUT NOTICE

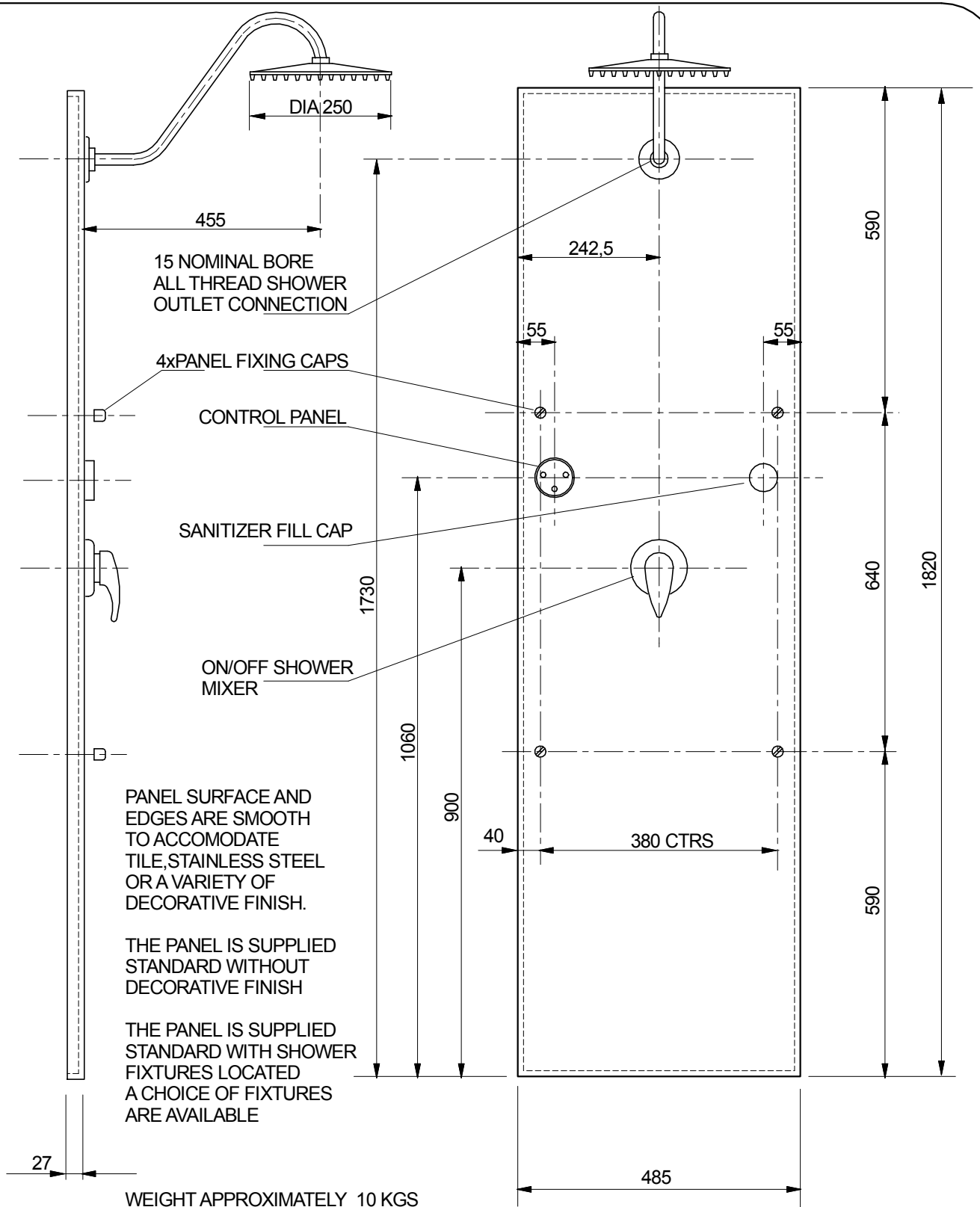

NOTE: TOWER COVER PANEL FIXES TO EQUIPMENT TOWER AND SECURED IN PLACE BY (4) FOUR FIXING CAPS

A WATER SPRAY POLYMER PROTECTIVE SEAL IS COMPRESSED BETWEEN COVER PANEL AND TOWER.

TOWER COVER PANEL IS REMOVABLE FROM WITHIN THE SHOWER ALLOWING ACCESS TO EQUIPMENT LOCATED IN THE TOWER

TITLE: TOWER COVER PANEL

QUENCH SOLUTIONS PTY LTD

ALL DIMENSIONS IN MILLIMETERS

Melbourne Australia

ph: (03)9786 7887 www.quenchshowers.com

SCALE: 1:5

MATERIAL : MOULDED SANITARY GRADE POLYESTER (REINFORCED FIBREGLASS)

DRG No. Q2R1-003 5of5

NOTE. THIS DRAWING IS TO BE USED AS A GUIDE ONLY AND IS SUBJECT TO CHANGE WITHOUT NOTICE